

The Passing Track

September 2013

Newsletter of the Rogue Valley Model Railroad Club

PO Box 1362—Medford, OR 97501

Home page is <http://rvmrc.net>

Operating Session with Eugene Club

They couldn't get enough operating during their last visit, so the Eugene Club came back for another session. They are getting to know the track plan and the important points to switching the different areas. We were glad to have them come back and hope they'll do it again.



Crossing Flashers in White City

The redesign of parts of White City has created the need for several sets of signaled crossings to support switching operations. These crossings do not require gates, signal flashing units are sufficient. Since these signals will cover industrial tracks, conventional crossing signal control boards with four optical sensors will not work properly. What is needed is a circuit which the operator uses to turn on on the signals when the switching operation begins. The club members did not want to have to turn off the flashers manually. Some form of timer was needed to keep the signals going for a fixed period of time. The circuit below contains 3 elements: An oscillator which provides the ½ second flash rate, signal driver section which provides the current to drive the LEDs in the signals, and a timer circuit which turns on the circuit for 40 seconds and then shuts it off. The signals are activated by a push button on the facia. Please note this circuit does not use the common anode or common cathode wiring setup for the signals. This is not an issue if you assemble your own or use the kits from Oregon Rail. A slightly more complicated circuit which can drive common cathode or common anode circuits will be shown in the next issue. The 'chips' are LM555 IC's. The circuit elements are based on circuits found on the internet www.discovercircuits.com , home.cogeco.ca and "IC Timer Cookbook, by W. Jung, SAMS .

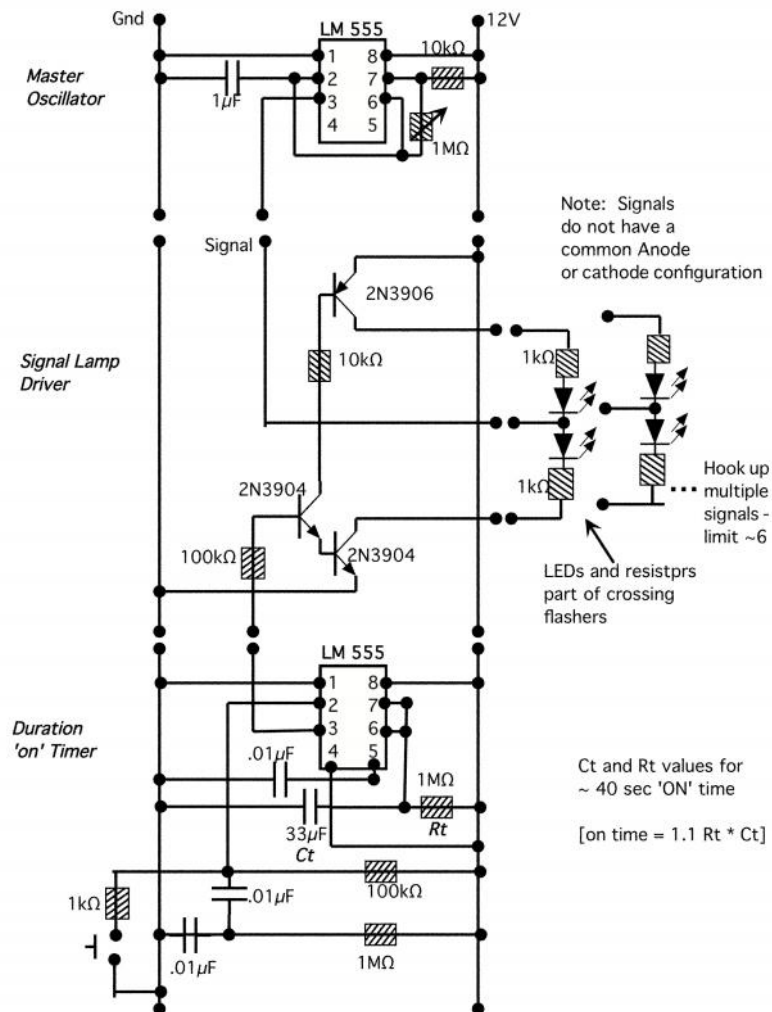

Changes in Butte Falls Area

Here is a sneak peak at the new scenery behind Butte Falls. Larry & Dave are doing a good job.



Looking Ahead

Annual Train Show : November 30 – December 1. Be sure to set aside the dates. We need people to help set up, operate and tear down the modular layout as well as sign-up for some of the show tasks. The income from this show is a major source of income for the club so your support is needed. There will be a signup sheet at the club for you to indicate what jobs you are willing to do, See Bruce for details. The show is a lot of fun to walk around and view the different modular layouts which are operating. There are also a large number of vendors selling a wide variety of railroad related products.

Operating Sessions

This fall we will be running operating sessions the [second](#) Saturday of each month. Since a complete set of runs must be completed to keep the cards and car locations in sync, we really need a full crew. So plan on coming and moving some freight. If you haven't tried it before, come and see how it works. There are easier jobs and people to help you. If you're new at it, don't volunteer for the Crater or Pellican yard jobs. The haulers are fun, (if only the other trains would get out of the way so you could 'haul'). The Medco job is fun and a good place to start, as long as the dastardly dispatcher doesn't run a stack train through Medco. Check with Bruce for the details of the start time.

Picnics

There were two picnics this summer for club members. The RVMRC club picnic was held on July 14 and the Medford Railroad Park picnic, which includes all the clubs in the park, was held on August 31. A good time was had by all and the food was great. The live steamers offered train rides during the picnic. The RVMRC did not reciprecate, stating that our tunnels were too small for people to fit through.

I wonder how many 4400 hp (Genesis) units it would take to pull a person on our layout. The person would have to have very good balance and we would have to find better wheel sets and trucks to handle the load. A 160 lb person would represent a 52,600 ton load. Who can figure that out? If you do, let me know and we'll put it in the FYI section of the newsletter.



FYI

Anyone interested in getting a club shirt, please contact Bruce McGarvey (541-890-8145) At this time, only a couple of people have signed up and we can not meet a minimum quantity, even with the club's reserve stock order.

RAILROAD TIME CARDS 2013

Sep 13 – *“Fire Laddies: The History of the Ashland Fire Department”* – Don Paul, retired assistant fire-chief. Second Friday Ashland Historic Railroad Museum program at the Ashland Public Library’s Gresham Room. Program starts at 6:30 pm.

Sep 21 - 22 – 18th Annual Open House, Eastern Cascades Model Railroad Club and Central Oregon Area Live Steamers, Bend, Ore. 10 am – 4 pm. HO scale layout plus ride the outdoor 1½” scale RVMRC Passing Track

railroad – one quarter mile of track on five forested acres. Info: 541-317-1545 or

<http://www.ecmrr.org/default.aspx>

Sep 28 – 29 – The Gears Show 2013, Rail Heritage Center, 2250 SE Water Ave, Portland, Ore. The Pacific Northwest’s Premier gas and steam show featuring working models and displays of incredible craftsmanship! Info: www.oregongears.org

Oct 5 - 1st Division PNR Mini-Meet, hosted by Gene Neville and the Corvallis Society of Model Engineers at Prince of Peace Community Church, 7234 NE Arnold Ave, Adair Village, Ore. Meet opens at 8 AM, program begins 9 AM. Clinics, model contest, door prizes and layout tours. For more details, check in on 1st Division web site at <http://pnr.nmra.org/1div/>

Oct 11 – “*Ashland’s Great Curve Ball*” – Joe Peterson. Peterson teaches classes of U.S. History at Ashland High School and U.S. History at SOU as an adjunct professor. Second Friday Ashland Historic Railroad Museum program at the Ashland Public Library’s Gresham Room. Program starts at 6:30 pm.

Nov 8 – “*Murder in the Lower Berth*” – Larry Mullaly. Mullaly is a published railway historian and a member of the Southern Oregon chapter of the National Railway Historical Society. Second Friday Ashland Historic Railroad Museum program at the Ashland Public Library’s Gresham Room. Program starts at 6:30 pm.

Nov 30 – Dec 1 – 36th Annual Rogue Valley Railroad Show, Medford Armory, 1701 So. Pacific Hwy, Medford, Ore. Sat 10-5, Sun 10-4. Model railroad displays, exhibits, swap meet, door prizes and raffles. Proceeds benefit the Medford Railroad Park. Info: Bruce iwcr@charter.net or 541-890-8145 and Bill 541-821-5547.

Looking ahead:

Mar 2014 - 1st Division PNR Mini-Meet, hosted by Nick Lehrbach and his Roseburg Crew. Details coming.

Aug 23 - 29, 2015 – 2015 NMRA National Convention, Portland, Oregon. Double Tree by Hilton Hotel Portland. More info at <http://www.nmra2015portland.org/>

Aug 28 – 30, 2015 - National Train Show, held in conjunction with the convention, at the Portland Expo Center.

(09/02/2013 Sept.PT-bhm)



It's a Bad Day when:

Your twin sister forgets your birthday...

You call suicide prevention and they put you on “hold”...

You find your grandson playing with your favorite brass locomotive.....in the bathtub...

As found in the April 1980 **Passing Track**.